

इंटरनेट

मानक

Disclosure to Promote the Right To Information

Whereas the Parliament of India has set out to provide a practical regime of right to information for citizens to secure access to information under the control of public authorities, in order to promote transparency and accountability in the working of every public authority, and whereas the attached publication of the Bureau of Indian Standards is of particular interest to the public, particularly disadvantaged communities and those engaged in the pursuit of education and knowledge, the attached public safety standard is made available to promote the timely dissemination of this information in an accurate manner to the public.

“जानने का अधिकार, जीने का अधिकार”

Mazdoor Kisan Shakti Sangathan

“The Right to Information, The Right to Live”

“पुराने को छोड़ नये के तरफ”

Jawaharlal Nehru

“Step Out From the Old to the New”

IS 5880 (1970): Stand, Saline-Cum-Irrigator [MHD 12: Hospital Equipment]



“ज्ञान से एक नये भारत का निर्माण”

Satyanarayan Gangaram Pitroda

“Invent a New India Using Knowledge”



“ज्ञान एक ऐसा खजाना है जो कभी चुराया नहीं जा सकता है”

Bhartrhari—Nitiśatakam

“Knowledge is such a treasure which cannot be stolen”

BLANK PAGE





Indian Standard
**SPECIFICATION FOR
STAND, SALINE-CUM-IRRIGATOR**

- 1. Scope** — Dimensions and other requirements for saline-cum-irrigator stand.
- 2. Materials**
 - 2.1 Tube** — As given in 2.1 of IS : 4033-1968 ' General requirements for hospital furniture '.
 - 2.2 Rod and Bush** — Mild steel, cold-rolled or hot-rolled quality.
 - 2.3 Castors** — Conforming to designation HN50 of IS : 4034-1968 ' Specification for castors for hospital equipment '.
 - 2.4 Base** — Cast iron.
- 3. Shape and Dimensions** — As shown in Fig. 1 (see page 2).
- 4. Manufacture** — The stand shall consist of a cast iron pedestal and an upright tubular member, fitted at right angles to each other as shown in Fig. 1. All the four ends of the pedestal shall be fitted with castors of size 50 mm. The upright member shall receive the rod support through a mild steel bush. The locking arrangement for the rod support and other fittings (for tray, wash bowls and douche) shall consist of a mild steel bolt pressing on the rod support or the upright member through the mild steel bush. The inside of the bush shall be free from burrs and sharp edges, so as to allow the rod support to operate smoothly. Further, the rod shall be plated chromium over nickel in accordance with Service Grade No. 3 of IS : 1068-1968 ' Specification for electroplated coatings of nickel and chromium on iron and steel (first revision) '. The accessories at X, Y and Z in Fig. 1 shall be optional and shall be supplied if desired by the purchaser. The overall assembly shall be stable and sturdy. The stand shall also conform to the requirements laid down in 4.1 of IS : 4033-1968.
- 5. Finish** — As specified in 5 of IS : 4033-1968.
- 6. Tests**
 - 6.1 Adhesion Test** — Shall be conducted as prescribed in 6.1.1 of IS : 4033-1968.
 - 6.2 Performance Test** — Shall be conducted as prescribed in 6.1.2 of IS : 4033-1968 and the performance shall be determined without putting any additional load.
- 7. Marking** — As specified in 7 of IS : 4033-1968.
 - 7.1 ISI Certification Marking** — Details available from the Indian Standards Institution.
- 8. Packing** — As specified in 8 of IS : 4033-1968.

Adopted 21 December 1970

© April 1971, ISI

Gr 1

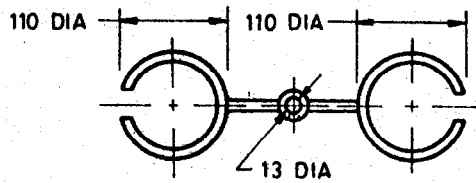
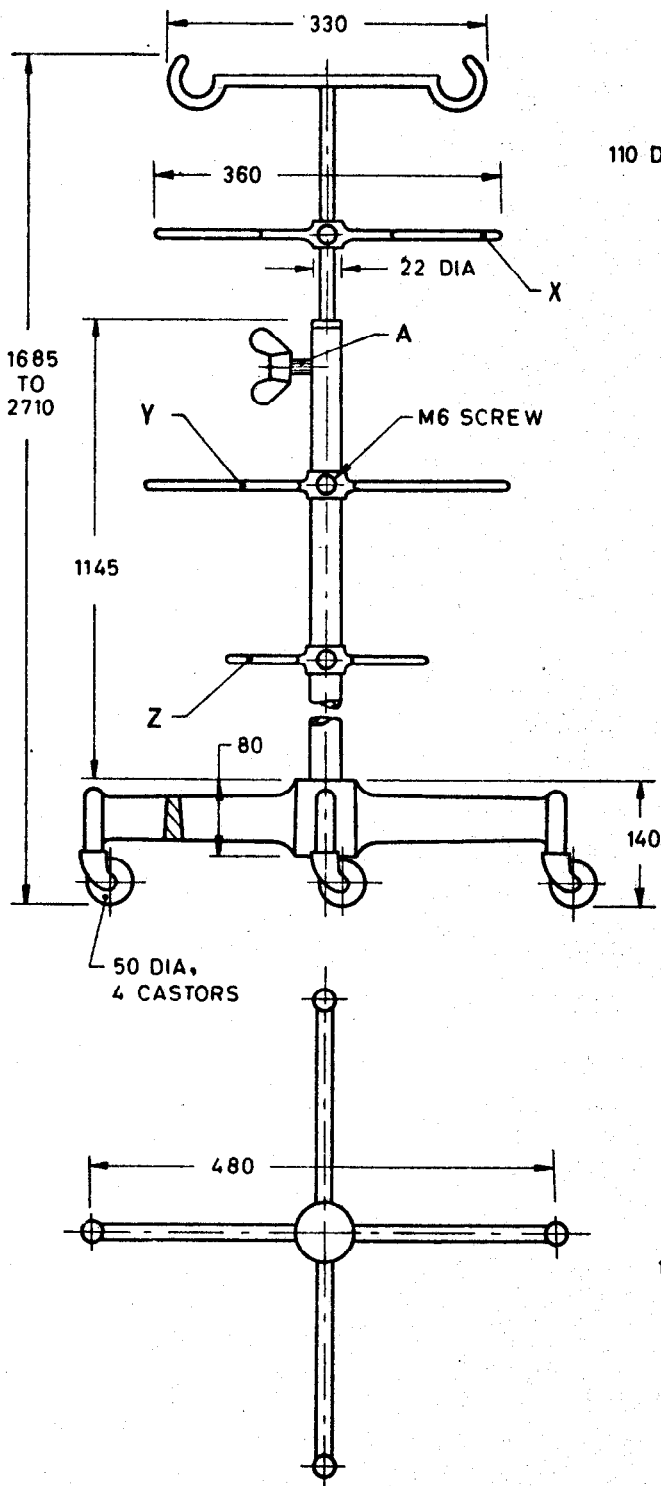

TOP VIEW OF X

TO ACCOMMODATE
200 TOP DIA WASH BOWL,
IS: 3994-1967*

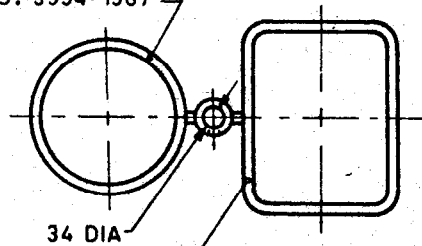

TO ACCOMMODATE
200 X 150 X 50
INSTRUMENT TRAY,
IS: 3993-1967†

TOP VIEW OF Y

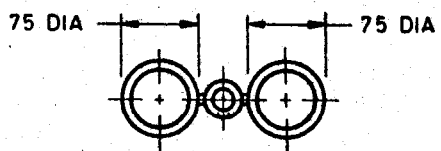

TOP VIEW OF Z

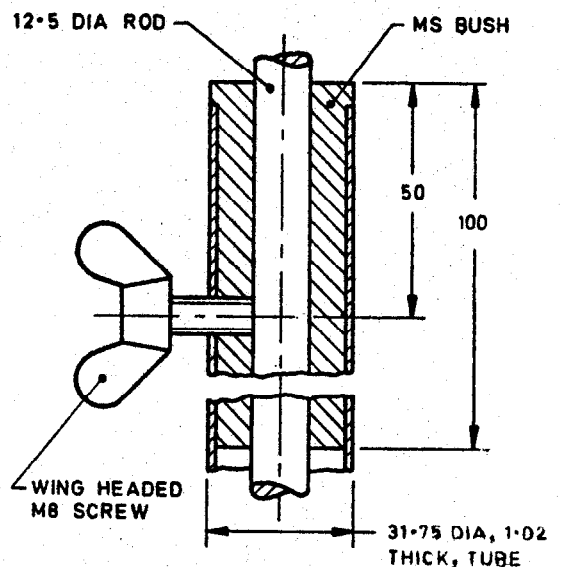

DETAIL AT A

*Specification for bowls, wash.
†Specification for trays, instrument.

All dimensions in millimetres.

FIG. 1 STAND, SALINE-CUM-IRRIGATOR